

NexLED III – LED Bulkhead Luminaires for use with 24v Inotec CBS (Ex ec)

ATEX, IECEx and UKEX



INSTALLATION, OPERATION AND MAINTENANCE INSTRUCTIONS

Important: Please read these instructions carefully before installing or maintaining this equipment. Good electrical practices should always be followed, this data should be used as a guide only.

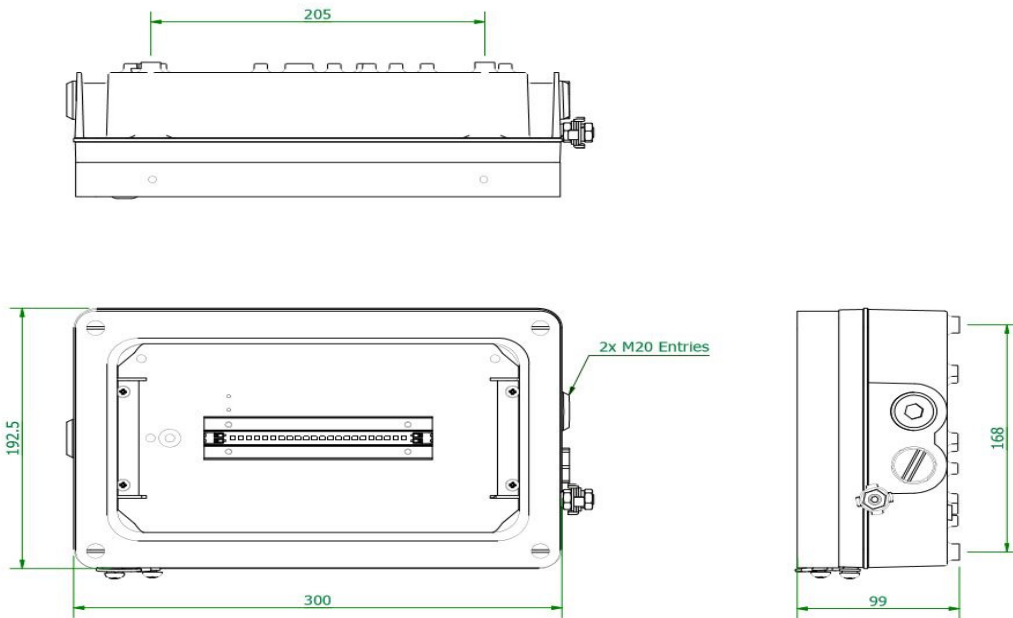
Technical Drawing:





0.0 Specification	
Type Of Protection	Ex ec, (non-sparking). Ex tc,
Protection Standards	EN/IEC 60079-0, EN/IEC 60079-7, EN/IEC 60079-31
Area Classification	Zone 2 areas to EN/IEC 60079-10-1, Zone 22 areas to EN/IEC 60079-10-2.
Installation	EN/IEC 60079-14
Certificate	Type Examination Certificate CML 20ATEX3047 IECEx Certificate of Conformity IECEx CML 20.0005 Type Examination Certificate CML 21UKEX3512
Equipment Coding	Ex ec IIC T6 Gc Ex tc IIIC T53°C Dc -15°C ≤ Ta ≤ 50°C
ATEX/ UKEX Coding	Ⓜ II 3 G D
Ingress Protection	IP66/67 to EN/IEC 60529
CE Mark  	<p>The CE marking of this product applies to "The Electrical Equipment (Safety) Directive", "The Electromagnetic Compatibility Directive", the "Waste Electrical and Electronic Equipment Directive" and the "Equipment and Protective Systems intended for use in Explosive Atmospheres Directive". [2014/35/EU, 2014/30/EU, 2012/19/EU and 2014/34/EU respectively].</p> <p>The UKCA marking of this product applies to "The Electrical Equipment (Safety) Regulations 2016", "The Electromagnetic Compatibility Regulations 2016", the "Waste Electrical and Electronic Equipment Regulations 2012" and the "Equipment and Protective Systems intended for use in Explosive Atmospheres Regulations 2016"</p> <p>The Equipment is declared to meet the provisions of the ATEX directive (2014/34/EU) by reason of the Type Examination/EU Type Examination and meets the UK statutory requirements SI 2016 No.1107 and compliance with the Essential Health and Safety Requirements. M Poutney Technical Manager</p>

SPECIAL CONDITIONS FOR SAFE USE

None

1.0 Introduction – Zone 2 & Zone 22, Ex ec, Ex tc LED Luminaire
General

The Chalmit NexLED 3 24v Inotec brings the very latest in lighting technology. It is a compact light source that uses ultra-bright light emitting diodes in 4K or 5K options to provide light on mains failure. The electronics are housed in an impact and corrosion resistant marine grade aluminium enclosure with a toughened glass lens. The control gear is electronic with regulated lamp output. The LEDs work equally well at low temperatures as they do at high, giving a product with very low overall power consumption.

Note: The ratings are listed in TABLE A

Wiring Diagram

Typical NL3C/01L/LE/24V

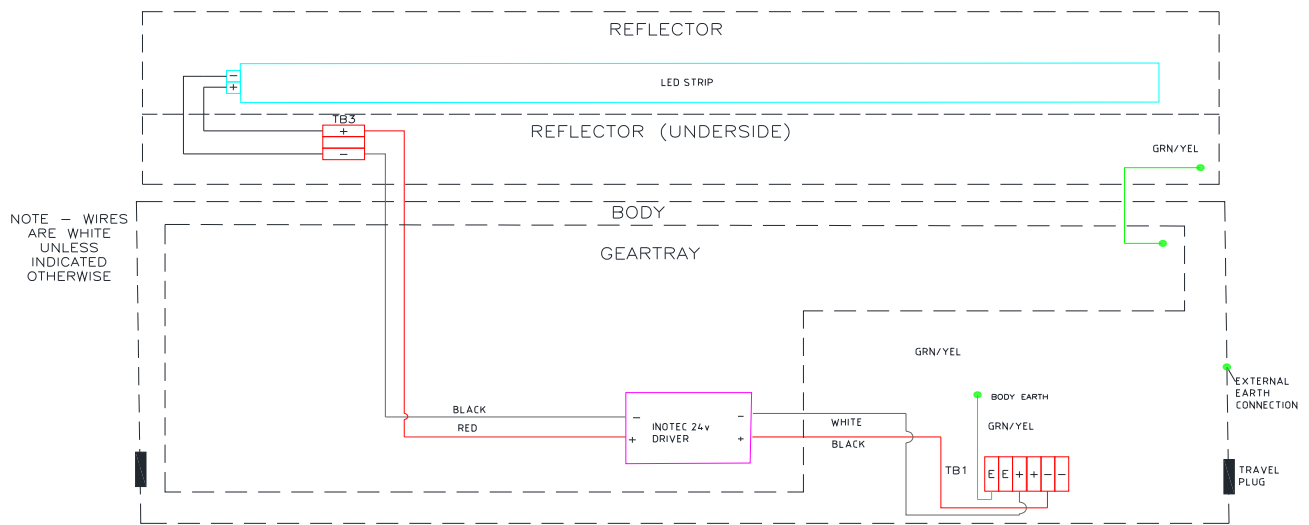

2.0 Storage

To optimise lifetime, luminaires should be stored in cool dry conditions preventing ingress of moisture and condensation between -15°C to $+50^{\circ}\text{C}$

3.0 Installation and Safety

3.1 General

There are no health hazards associated with this product whilst in normal use. However, care should be exercised during the following operations. Installation should be carried out in accordance with relevant EN / IEC standard or the local hazardous area code of practice, whichever is appropriate.

These instructions should be read carefully before attempting to install the luminaire. Copies of these instructions should be held in a safe place for future reference.

It is the responsibility of the installer to ensure that the apparatus selected is fit for its intended purpose and that the installation, operation and maintenance of the apparatus complies with regulations, standards or codes of practice applicable.

Any specific installation instructions must be referred to. In the UK, the requirements of the Health and Safety at Work Act must be met, and electrical work associated with this product must be in accordance with the "Manual Handling Operations Regulations" and "Electricity at Works Regulations 1989". Your attention is drawn to the paragraphs (i) 'Electrical Supplies', (ii) 'Electrical Fault Finding and Replacement' and (iii) 'Inspection and Maintenance'. The luminaires are Class 1 and should be effectively earthed.

Certification details on the rating plate must be verified against the application requirements before installation. The information in this leaflet is correct at the time of publication. The manufacturer reserves the right to make specification changes as required.

3.1.1 Use in Combustible Dust Atmospheres

Where the equipment is used in ignitable dust atmospheres reference must be made to the selection and installation standards in order that the equipment is used correctly. This applies to the de-rating of surface temperature for use where dust clouds may be present. Dust layers should not be allowed to accumulate on the fitting surface and good housekeeping is required for safe operation. Dust in layers has the potential to form ignitable clouds and to burn at lower temperatures.

Refer to EN/IEC 60079-10-2 & EN/IEC 61241-14 for additional details of selection, installation and maintenance.

3.1.2 Hybrid Mixtures – Gas plus Dust

Where Hybrid mixtures exist as defined in EN/IEC1127 as a potentially explosive atmosphere, consideration should be given to verifying that the maximum surface temperature of the luminaire is below the ignition temperature of the hybrid mixture.

3.2 Tools

Suitable spanners for installing cable glands.
3mm flat blade screwdriver. 12mm flat blade screwdriver.
8mm nut driver Pliers, knife, wire strippers/cutters.
Replacement: T20 Screwdriver

3.3 Electrical Supplies

A maximum voltage variation of +25%/-25% on the nominal can be tolerated.

Warning: *Luminaires are assessed and/or tested for EMC requirements. This is based on the disposition of entry cables and, where appropriate, through wiring arrangements as supplied or specified. Users must take care not to introduce wiring into parts of the apparatus materially different to that which could be reasonably inferred from the disposition of fixed supply terminals and specified wiring.*

3.4 Light Emitting Diode (LED)

LED's are supplied in 800 Lumen option with the colour temperature of 4K or 5K.

The LEDs are maintenance free and at 25°C can last up to a calculated 133,000 hrs at L70. Therefore, in many applications replacement of the LED module will be unnecessary. If replacement is required ensure supply is isolated before commencing work. Remove the front cover and then remove the LED array and mounting plate assembly by disconnecting the cables. Assembly is the reverse of disassembly making sure that the earth is connected and ensuring the gasket/glass mating surfaces are clean and cables are not trapped.

3.5 Control gear

System life > 100.000hrs

Therefore, replacement of this component should be unnecessary. If replacement is required ensure mains supplies are isolated before commencing work. Remove the front cover then drop down the LED array.

The LED array should be dis-connected first by removing wires from the terminal block, then using an 8mm nut driver the hanging straps should be removed.

The geartray can now be taken out with the removal of the 2 Torx head screws.

Assembly is the reverse of disassembly, making sure that the earth is connected and ensuring the gasket/glass mating surfaces are clean and cables are not trapped.

3.6 Mounting

Luminaires should be installed where access for maintenance is practical and in accordance with any lighting design information provided for the installation. Mounting is by 4 holes in the base of the body casting external to the gasket. These should be secured with lock washers or self-locking nuts and bolts and are accessed by removing the front cover. Any mounting attitude may be used.

3.7 Cabling and Cable Glands

3.7.1 Cables

The maximum conductor size is 4mm². Internal earth point is provided next to the main terminal block. 300/500V cable ratings are adequate and no special internal construction is necessary. The standard looping cable size is up to 4mm². The selection of cable size must be suitable for the fuse rating. Terminals are supplied with suitability for looping. Where looping is used the maximum current is 16A. Terminals are accessed by removing the front cover and LED array assembly. Maximum cable temperature rise is 20°C above ambient.

3.7.2 Cable Gland

The installer and user must take responsibility for the selection of cables, cable glands and seals.

The product is certified for ATEX, IECEx and UKEX and to comply with the certification for installation cable glands and sealing plugs must be ATEX, IECEx or UKEX certified depending on site requirements.

Three tapped cable entries are provided, two with a plug and seal suitable for permanent use, the other with a travelling plug not suitable for use in service. Sealing plugs are similarly rated and a tool must be used for their removal. Cable entries are M20x1.5. Cable glands and sealing plugs must have ATEX approval or be certified to EN60079-0. For installation outside the EU suitable cable glands in accordance with IEC 60079-0 will meet the technical requirements.

The cable and gland assembly when installed must maintain a minimum of IP66/67 rating.

The cable glands must be suitable for the application. Where brass cable glands are used in a corrosive environment, cadmium or nickel plating should be used.

3.8 Exit Sign Version

To apply the exit label assembly, loosen the M6 wire rope fastener from the front cover, position the assembly and fix in place using the M6 fasteners provided. The illuminated height of the label is 140mm with a maximum visible distance of 28m as defined by EN1838

4.0 Inspection and Maintenance

Visual inspection should be carried out at a minimum of 12 monthly intervals and more frequently if conditions are severe. The time between lamp changes could be very infrequent and this is too long a period without inspection.

4.1 Routine Maintenance

Visual tests and checks should be carried out at intervals described by the appropriate regulations, EN/IEC 60079-17, and should include the following:

Check that the LEDs are working.

Check for mechanical damage/corrosion.

Check for loose connections including earthing.

Check for undue accumulations of dust or dirt.

Verification of tightness of fixing, glands, blanking plugs etc.

Check for unauthorised modifications.

Check condition of enclosure gasket and fastenings.

Check for any accumulation of moisture.

Periodic inspection of the enclosure seal should be carried out to ensure that the seal is sound.

If the luminaire has been subject to abnormal conditions, for example, severe mechanical impact or chemical spillage, it must be de-energised until it has been inspected by an authorised and competent person. If in doubt, the unit should be returned to Chalmit for examination and, if necessary, replacement.

Before re-assembling, all connections should be checked, and any damaged cable replaced.

4.2 Electrical Fault Finding and Replacement (Refer EN / IEC 60079-19)

The supply must be isolated before opening the luminaire.

Any live fault finding must be done by a competent electrician and, if carried out with luminaire in place, under a permit to work.

The electronic drivers are approved components.

On re-assembly, all faulty/damaged wiring should be replaced, and connections checked.

5.0 Disposal of Material

Any disposal must satisfy the requirements of the WEEE directive [2012/19/EU and Regulations 2012] and therefore must not be treated as commercial waste. The unit is made from combustible materials; the control gear contains plastic parts and electronic components. All electrical components and the body parts may give off noxious fumes if incinerated. Take care to render these fumes harmless or avoid inhalation. Any local regulations concerning disposal must be complied with.

6.1 LED's

LED's in modest quantities are not "special waste". They should be broken in a container to avoid possible injury from fragmentation. Avoid inhaling dust. This applies to the UK; there may be other regulations on disposal operating in other countries.

Important: *Do not incinerate LED's.*

Table A

Table A - Series Standard Circuit.					
Model	No. Of LED Strips	Nominal Volts	Lumen	Nominal Circuit Power (W)	Line Current (Amp)
01L	1 x 140mm	24Vdc	816	5	0.3 – 0.22A





To comply with the Waste Electrical and Electronic Equipment directive 2012/19/EU and regulations 2012 the apparatus cannot be classified as commercial waste and as such must be disposed of or recycled in such a manner as to reduce the environmental impact.

Chalmit Lighting is a leading supplier of Hazardous Area lighting products

	<p>CHALMIT LIGHTING PO Box 5575 Glasgow, G52 9AP Scotland</p>	
<p>Telephone: +44 (0) 141 882 5555 Fax: +44 (0) 141 883 3704 Email: info@chalmit.com Web: www.chalmit.com</p>	<p>Registered No: 669157 Registered Office: Cannon Place 78 Cannon Street London EC4N 6AF UK</p>	

For technical support, please contact: techsupport@chalmit.com

Note: Chalmit Lighting reserves the right to amend characteristics of our products and all data is for guidance only.

	EU/UK-Declaration of conformity		
	UE-Déclaration de conformité		
	EU-Konformitätserklärung		
Manufacturer	Chalmit	Address	388 Hillington Road, Glasgow. G52 4BL Scotland UK
Product	NexLED III LED		
Notified Body	CML B.V. 2776		
Type Examination Certificate	CML 20ATEX3047		
Approved Body	Eurofins CML 2503		
Type Examination Certificate	CML 21UKEX3512		
ATEX/UKEX Coding	 II 3 G D		
ATEX/UKEX Classification	Group II Category 3 GD		
Equipment Coding	Ex ec IIC T6 Gc. Ex tc IIIC T53°C Dc -15°C ≤ Ta ≤ 50°C		
Ingress Protection	IP66/67		
The technical basis, with respect to equivalence of			
La base technique, en ce qui concerne l'équivalence de			
Die technische Grundlage hinsichtlich der Normen			
Protection Standards EN 60079-0:2018, EN 60079-7:2015, EN 60079-31:2014			
Area Classification EN 60079-10-1, EN 60079-10-2.			
of compliance with the EHSRs is valid as there are no changes which materially affect the state of technological progress of the product.			
en conformité avec les EESS est valide puisqu'il n'y a aucun changement qui affecte matériellement l'état de l'évolution technologique du produit.			
zur Erfüllung der GSGA ist gegeben, da keine Änderungen erfolgt sind, die einen Einfluss auf den technischen Stand des Produkts haben.			
Terms of the directive:		Standard & Date Certified to	Standards Date Declared to
Prescription de la directive:		Standard & date certifiée à	Normes date Déclaré
Bestimmungen der Richtlinie:		Standard & Datum Zertifiziert nach	Standards Datum erklärt
2014/34/EU SI 2016 No.1107	Equipment and protective systems intended for use in potentially explosive atmospheres.	EN 60079-0: 2018 EN 60079-7: 2015 +A1:2018	
2014/34/UE	Appareils et les systèmes de protection destinés à être utilisés en atmosphères potentiellement explosibles.	EN 60079-31: 2014	
2014/34/EU	Geräte und Schutzsysteme zur bestimmungsgemäßen Verwendung in explosionsfähigen Bereichen.		
2014/30/EU Regulations 2016	Electromagnetic compatibility	EN 55015 : 2019	
2014/30/UE	Compatibilité électromagnétique	EN 61547 : 2009	
2014/30/EU	Elektromagnetische Verträglichkeit	EN 61000-3-2 : 2019	
2014/35/EU Regulations 2016	Low voltage equipment	EN 60598-1 : 2015	
2014/35/UE	Équipements électriques à bas voltage	EN 60598-2-5 : 2015	
2014/35/EU	Niederspannungsgeräte / -systeme	EN 60529 : 1992+A2:2013	
2012/19/EU Regulations 2012	Waste of electrical and electronic equipment		
2012/19/UE	Déchets d'équipements électriques et électroniques		
2012/19/EU	Entsorgung der elektrischen und elektronischen Geräte / Systeme		



2011/65/EU Regulations 2012	RoHS II Directive		

On behalf of the Chalmit, I declare that, on the date the equipment accompanied by this declaration is placed on the market, the equipment conforms to all technical and regulatory requirements of the above listed directives.

En tant que représentant du fabricant Chalmit, je déclare qu'à la date où les équipements accompagnant cette déclaration sont mis sur le marché, ceux-ci sont conformes à toutes les dispositions réglementaires et techniques des directives énumérées ci-dessus.

Hiermit bestätige ich, im Namen von Chalmit, dass am Tag der Lieferung des Produkts/der Produkte zusammen mit dieser Erklärung das Gerät/die Geräte alle technischen und regulativen Anforderungen der oben aufgeführten Direktiven erfüllt.

Name and Date Mark Poutney 10/11/2021
Nom et Date
Name und Datum

Technical Manager
Directeur technique
Technischer Leiter

Quality Assurance Notification by: **SGS Fimko OY 0598**
Notification d'assurance qualité par:
Qualitätssicherungsnotifikation durch:

Quality Management System Accreditation:

ISO 9001

Système de Management Qualité Accréditation:
Qualitätsmanagementsystem Akkreditierung:
Environmental Management System.
Système de gestion de l'environnement.
Umwelt kontroll system.

ISO 14001
by/par/durch
Lloyd's Register
LRQ 4005876

UKCA Quality Assurance Notification by: SGS Baseefa 1180

Certificate No./Certificat N°/Zertifikat Nr.